



## 2021 WinterSeries

### PREAMBLE:

This series articles governing MX5RacingNZ has been prepared by the Manawatu Car Club to govern the building and racing of low-cost Mk1 1600cc Mazda MX5 sports cars in New Zealand.

The MX5 Racing NZ Series is organized and held in accordance with the MotorSport NZ National Sporting Code, the standing regulations and any supplementary regulations applicable to and issued by the organisers of each Round of the Series.

These articles and technical regulations are to be read in conjunction with:

- The National Sporting Code (NSC) and its appropriate Appendices and Schedules,
- The Event Supplementary Regulations issued by the inviting Clubs.

### RULE CHANGES

Rule	Reason for change
<p><b>3.5 Eligibility All drivers and entrants must be members of the Manawatu Car Club</b></p>	To improve communication with MX5RacingNZ members as a Class and sub-committee of the Manawatu Car Club
<ul style="list-style-type: none"> <li>• <b>Series production NA8CE, NB6CE and NB8CE Mazda MX5s built between 1994 and 2005 may compete without scoring points, provided they are naturally aspirated and conform with the Safety Equipment Requirements 15.4 of these Articles</b></li> </ul>	To invite other MX5 drivers to join the races with the aim to forming equivalency rules to include their cars for next season
<ul style="list-style-type: none"> <li>• <b>Minimum Racing Weight of NA8CE, NB6CE and NB8CE Mazda MX5s shall be 1060kg in racing trim including the driver.</b></li> </ul>	To allow for performance differences between the original NA6CE model and the newer cars
<ul style="list-style-type: none"> <li>• <b>15.20.1 Tyres are to be Hankook Ventus RS4 195-50R 15 and shall have a minimum tread depth in accordance with Schedule A 4.9 (3) (b) All tyres shall have a minimum tread groove depth of 1.5mm as defined by the manufacturers tread depth indicators within all grooves around the entire circumference of the tyres road contact surface.</b> <b>Note: Toyo R888 and R888R 205/50/15 tyres are now obsolete. Points will not be awarded to drivers using these tyres</b></li> </ul>	Confirms the control tyre for the class
<ul style="list-style-type: none"> <li>• <b>Discounted Hankook Tyres available from <a href="mailto:tremaineworkshop@inspire.net.nz">tremaineworkshop@inspire.net.nz</a></b></li> </ul>	Manawatu Car Club discount is available for all Hankook Tyres purchased via Tremaine Energy

## 1. INTERPRETATION:

In these articles, the following expressions shall have the meanings set out:

“**Series**” means the MX5RacingNZ Series, being a series of events, the results of which are aggregated to form a final result; and

“**MX5 Racing NZ**” means the MX5RacingNZ Race Class and sub-committee of the Manawatu Car Club; and

“**NSC**” means the National Sporting Code issued by MotorSport NZ from time to time; and

“**Round**” means a meeting or event consisting of a number of races that which qualifies for points as part of the MX5RacingNZ Series; and

“**Round Organiser**” or “**Inviting Club**” means the Motorsport NZ member club organizing a meeting and/or event which is a round of the series.

## 2. OBJECTIVES.

To promote and foster low cost, competitive, production car-based racing with an emphasis on rewarding driver skill as opposed to vehicle mechanical advantage.

## 3. ELIGIBILITY.

**3.1** All drivers shall hold a C1 Grade Competition license or higher and if the Entrant is other than the Driver, an Entrants Licence is required in the name of the Entrant.

**3.2** Eligibility shall be for vehicles complying with the specifications as detailed later in these articles.

**3.3** All Competitors/Entrants shall agree to submit their vehicle(s) for eligibility/safety scrutineering inspections as and when required by the appointed Series Scrutineer, and/or a MotorSport NZ licensed Technical officer. Any costs incurred during disassembly shall be met and accepted by the Competitor/Entrant.

**3.4** Official Series Seals maybe applied by the Series Scrutineer, at any time, to components and/or assemblies of components in compliance with Appendix Two, Schedule A, Article 3.7. Any applied seals shall be clearly detailed in the vehicle’s Motorsport NZ Logbook.

**3.5** All drivers and entrants shall be financial members of the Manawatu Car Club. Join here: <https://manawatucarclub.org.nz/get-involved/membership/>

## 4. SERIES STRUCTURE: WINTER SERIES

The 2021 MX5RacingNZ Winter Race series shall comprise of the following rounds;

Round	Date	Venue	Inviting Club	Event
1	6 <sup>th</sup> June 2021	Manfeild: Circuit Chris Amon	Manawatu	Winter Series Round 1
2	4 <sup>th</sup> July 2021	Manfeild: Circuit Chris Amon	Manawatu	Winter Series Round 2
3	8 <sup>th</sup> August 2021	Manfeild: Circuit Chris Amon	Manawatu	Winter Series Round 3
4	5 <sup>th</sup> September 2021	Manfeild: Circuit Chris Amon	Manawatu	Winter Series Round 4

The Series organiser reserves the right to either cancel or amend any rounds of the series due to force majeure without affecting in any way its power to award any title.

## 5. SERIES PERSONNEL:

5.1 The following personnel, or their approved assistant/s shall have the responsibilities and authorities set out:

### 5.1.1 MX5RacingNZ Series Coordinator:

**Name:** Jeremy Hoskins  
**Phone No:** 021 653771  
**Email:** [jerryhoskins007@gmail.com](mailto:jerryhoskins007@gmail.com)

Who shall have the authority of a series coordinator set out in the NSC and who shall be responsible for and authorized on behalf of MX5 Racing NZ to:

- A. Deal with all administrative matters pertaining to the Series; and
- B. Record and publish all Series points schedules; and
- C. Liaise with the inviting clubs on all matters pertaining to these Articles; and
- D. Ensure correct placement of decals on vehicles contesting the series; and
- E. Provide the Inviting club with grid positions where these differ from those detailed in Appendix four Schedule Z, Article 6.1. For Clubsport events this does not apply.
- F. Attend Stewards meetings if required

The Series Coordinator may appoint a Series Secretary to assist with the administrative duties in connection with the series.

### 5.1.2 MX5RacingNZ Series Secretary:

**Name:** Conrad Healy  
**Phone No:** 027 502 1990  
**Email:** [conrod.healy@gmail.com](mailto:conrod.healy@gmail.com)

### 5.1.3 MX5RacingNZ Series Scrutineer:

**Name:** Stu Hower  
**Phone No:** 027 444 7951  
**Email:** [autostripes@xtra.co.nz](mailto:autostripes@xtra.co.nz)

Who shall have the duties and authority of a Series Scrutineer as set out in the NSC and who shall be responsible for and authorized on the club's behalf to:

- a) Appoint appropriate Scrutineers to assist with inspections; and
- b) Deal with all technical matters pertaining to the Series; and
- c) Affix seals as and when deemed appropriate; and
- d) Inspect any competing vehicle within the Series in order to ascertain compliance with the technical regulations; and
- e) Assist competitors with technical inquires relative to the technical regulations applicable to their vehicle; and
- f) Liaise with Event Officials and Series Coordinators on any technical conformity issue for the class; and
- g) Be Judge of Fact on the technical regulations of the series

5.2 All correspondence shall be addressed to the Series Secretary who is authorised by MX5 Racing NZ to carry out all necessary administrative duties for the Series.

5.3 The **MX5RacingNZ Sub-Committee** to the Manawatu Car Club will consist of the Series Coordinator, the Series Secretary and the Series Scrutineer.

**5.3.1 Duties of the Sub-Committee:**

- a) To report to the Manawatu Car Club Committee the week following each race meeting in the MX5RacingNZ Winter series
- b) To assist competitors and entrants at race meetings
- c) To consider breaches of the technical regulations as reported to them by the Series Scrutineer
- d) To impose penalties of points deductions they deem appropriate.

**5.3.2** In the case of conflict of interest a neutral person will be appointed by the remainder of the Sub-Committee

**6. SERIES ENTRY**

**6.1** Entry into the Series shall be made on the official MX5RacingNZ series entry form. By entering the series all competitors/entrants agree to comply with these articles and the NSC.

**6.2** Entry to each Round of the Series (separate to the Series Entry) shall be made to the event organiser of the round, or Mazda Racing Series, on the official entry form for each round.

**6.3** MX5RacingNZ will endeavour to allocate a permanent number to each competitor for the series. All numbers on competing vehicles shall comply with the prescriptions of Appendix Two; schedule A, article 6.2 – Competition Numbers.

**6.4 Condition of Entry:**

**6.4.1** The Competitor/Entrant, by entering the series is deemed to be in acceptance of these series articles as they are presented, and shall be at all times responsible for their competing vehicle with respect to safety requirements under Schedule A, and eligibility requirements of MX5 Racing NZ.

**6.4.2** The Competitor/Entrant, by entering the series is deemed to be in acceptance of and will comply with any specific requirements of the official Series Sponsor/s as detailed within these articles.

**6.4.3** The Series Organiser reserves the right to accept or decline entries into the series as per NSC 21.

**7. POINTS STRUCTURE:**

**7.1** There shall be one points system applied to all results of the Series. Points will be recorded and published by the series Coordinator and will be allocated to all eligible competitors in the series on their overall finishing positions in each race at each round of the series.

**7.2** The points will be allocated as follows;

1st	75	11th	30	21st	10
2nd	67	12th	28	22nd	9
3rd	60	13th	26	23rd	8
4th	54	14th	24	24th	7
5th	49	15th	22	25th	6
6th	45	16th	20	26th	5
7th	42	17th	18	27th	4
8th	39	18th	16	28th	3
9th	36	19th	14	29th	2
10th	33	20th	12	30th	1

**AWARDS:**

**MX5 Racing NZ Winter Series.**

The driver whose totals the highest points score

from the results of the series will determine the MX5RacingNZ Winter Championship points and positions.

**8.1.2** Any ties will be resolved by the driver with the highest number of round wins, and in the case of a further tie the highest number of first placings, second placings and so on until a winner has been determined.

**8.1.3** Awards will be presented following the final round of the series as follows;

- Overall MX5RacingNZ Winter Series Champion
- Second place and
- Third place

## **9. ROUND FORMATS:**

### **9.1 MX5RacingNZ Winter Series.**

*MX5 cars will race in their own grid in the Winter Series at Manfeild.*

Qualifying.	10 minutes
Race 1.	6 laps Scratch based on qualifying results.
Race 2.	6 laps Double-spaced full reverse grid on the finishing positions of Race 1
Race 3.	6 laps handicap based on the Winter Series rules.

**9.2** MX5RacingNZ competitors will be scored on each race finish using the points table in 7.2 of these articles. This score will be totaled and once placings have been finalized the points table in 7.2 shall be applied to overall round placing to eligible competitors only.

## **10. TIMEKEEPING.**

**10.1** The round organiser shall provide the timing system for each event.

**10.2** If AMB Timing is used and a transponder is hired, it is the responsibility of the competitor to install in accordance with Schedule A, look after the equipment with due care and return at the end of the event. Any damage or loss is the responsibility of the competitor.

## **11. BREACH OF TECHNICAL REGULATIONS.**

**11.1** In the case of a breach or breaches of **Technical Regulations 15** penalties shall be applied by the MX5RacingNZ Committee by loss of points for race/races as deemed appropriate by the MX5 Racing NZ Committee. The Committee's decision is final.

## **12. PARC FERME:**

**12.1** At the conclusion of any qualifying session or race, drivers, upon directive by the Series Scrutineer or their appointed assistants, shall drive their competing vehicle directly (without any team personnel/crew intervention) from the track to the designated Parc Ferme. The location of Parc Ferme will be notified on the official event notice board.

**12.2** The series scrutineer may authorise entry of team personnel for the purposes of vehicle eligibility inspections.

## **13. DECALS**

**13.1** All Competitors shall ensure that their competing vehicle and apparel have the specified spaces reserved for the Series Register and the Series Sponsors at all rounds of the series and shall include;

- Windscreen banner.
- Both front guards at the rear and above front wheel arches

**13.2** One set of decals shall be provided free, replacements will be charged to competitors.

**13.3** Car identification shall be shown as follows in accordance with Schedule A Article 6.2 (1):

- The car number shall be shown on the doors;
- The car number and driver's name shall be shown on the left side of the windscreen;
- Each car may have a nick-name, to be located on the front bumper area near the badge mount.

#### **14. TELEVISION AND IN-CAR CAMERAS:**

**14.1** All in car camera installations shall be subject to inspection and approval by the Series Scrutineer and/or Chief Scrutineer of the meeting.

**14.2** Competitors are encouraged to use in car cameras for collecting series footage and make this available to MX5RacingNZ for promotional purposes.

**14.3** Any in-car camera footage should be made available to the Clerk of the Course or the Series Coordinator on request

#### **15. TECHNICAL REGULATIONS**

##### **PREAMBLE**

The overlying philosophy of these regulations is as follows:

- To always keep regulations simple, straightforward and along the lines of "it must remain standard unless specifically stated otherwise"; Efforts to bend, find or take advantage of loopholes in the rules will be deemed to not be in the spirit of the regulations. These regulations are presented on the basis that if a modification is not specifically permitted, then it is not allowed.
- To minimize compliance costs and ensure the Series emphasizes driver ability rather than mechanical advantage;
- To control the Series through these regulations to provide fair competition for all;
- To meet the objectives of the Series;

##### **15.1 GENERAL INFORMATION**

**15.1.1** This schedule shall be read in its entirety and shall take precedence over Appendix 2 Schedule A of the NSC excepting where an item is not specifically covered, in which case Appendix 2 Schedule A will apply.

**15.1.2** "OEM" means Original Equipment Manufacturer and refers to Mazda factory-supplied original components

**15.1.3** All competing vehicles to which these regulations apply shall have a valid MotorSport NZ logbook.

**15.1.4** Where any doubt may exist in understanding any regulation contained within this schedule, it will be understood that it is the competitor's obligation to enquire as to the correct interpretation.

- All technical eligibility and/or safety equipment enquiries shall be submitted in writing to the Series Scrutineer.
- A written reply will be provided.
- On matters of technical eligibility and/or safety compliance, a verbal statement will have no validity.

## **15.2 ELIGIBLE VEHICLES**

- The only vehicles eligible to compete shall be the series production NA6CE model Mazda MX5 built between 1989 and 1993 with a 1600cc engine. All vehicles should be of sound construction and good mechanical condition.
- Series production NA8CE, NB6CE and NB8CE Mazda MX5s built between 1994 and 2005 may compete without scoring points, provided they are naturally aspirated and conform with the Safety Equipment Requirements 15.4 of these Articles

## **15.3 MINIMUM RACE WEIGHT**

**15.3.1** All race vehicles shall respect the **Minimum Racing Weight** at all times during the competition

**15.3.2** The Racing Weight may be measured at any time during or at the conclusion of any qualifying session and/or race on the official scales of the event/meeting

**15.3.3** **Minimum Racing Weight** of NA6CE models shall be **960kg** in racing trim including the driver. **Minimum Racing Weight of NA8CE, NB6CE and NB8CE Mazda MX5s shall be 1060kg in racing trim including the driver.**

**15.3.4** Any ballast required to respect the minimum racing weight shall be securely bolted to the chassis in compliance with Schedule A

## **15.4 SAFETY EQUIPMENT REQUIREMENTS**

The following safety equipment **shall** be fitted to the competing car

**15.4.1** A roll cage shall be installed in full compliance with Schedule A.

The roll cage design is free but must include the following minimum members:

- a) Main Hoop
- b) Diagonal on main hoop from rear mount to above drivers head
- c) Minimum of a single door intrusion bar on each side positioned as close to the door covering as possible
- d) Minimum of a single bar in the centre of the roof
- e) Horizontal seat belt mounting bar

Material shall be MSNZ-Q29 steel only. ASME 4130 Alloy (Chrome Moly) is not permitted.

Refer to diagram below for typical standard rollcage design

**SECTION 3 - SAFETY CAGE / ROLLBAR DRAWING** (Refer instruction 3)

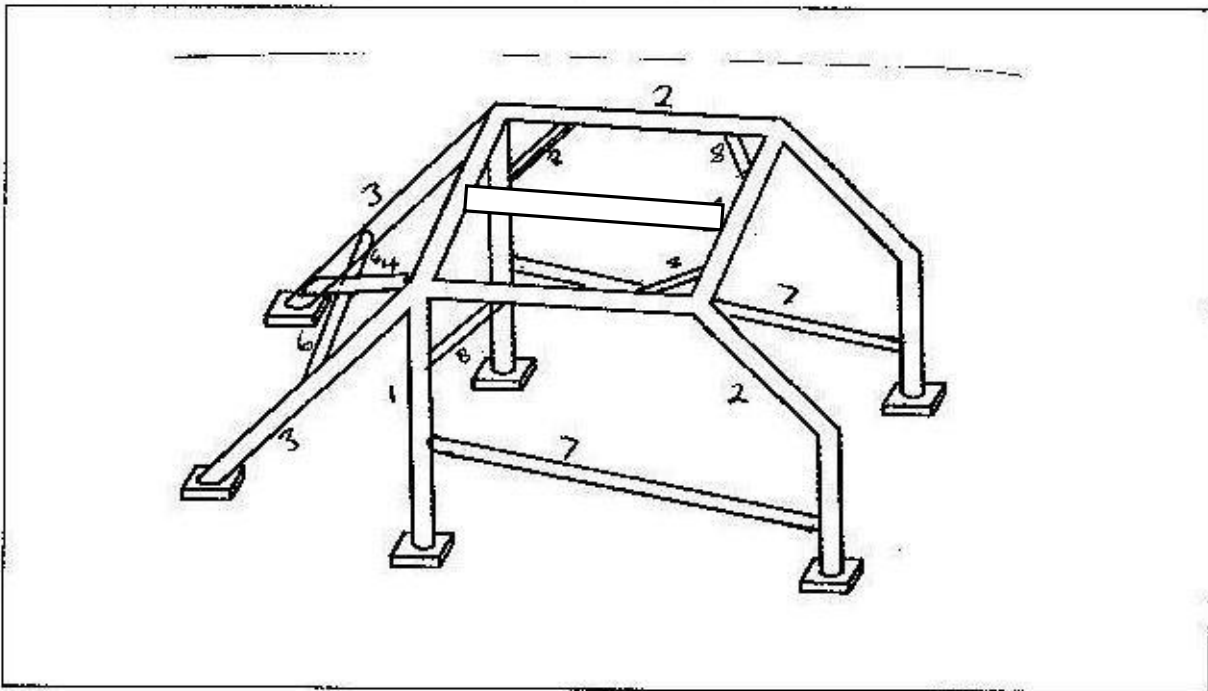

**15.4.2** A competition seat, safety harness and fire extinguisher shall be installed in full compliance with Schedule A

**15.4.3** A driver's window net shall be installed which must comply with Appendix Two Schedule A 4.5(1)

(a) Window nets shall close the window aperture to the steering wheel, and

(b) Be approved to an SFI standard or FIA requirements having the following characteristics:

- Minimum width of the strips: 19mm,
- Minimum size of the meshes: 25 x 25mm,
- Maximum size of the meshes: 60 x 60mm, and

(c) Shall incorporate a 'quick release' system operable from both inside and outside the vehicle.

### 15.5 FUEL

**15.5.1** Only MotorSport NZ approved unleaded fuels currently commercially available from a New Zealand service station forecourt pump may be used; **unleaded 91 octane (RON), unleaded 95 octane (RON), unleaded 98 octane (RON) and E10 98 Octane (10% Ethanol Blend).**

**15.5.2** Avgas (Aviation fuel), any unleaded Race gas, E85 (Ethanol blend) and any octane boosting/additive products, or fuels that are outside of the ones listed are deemed illegal.

**15.5.3** All competitors agree to fuel samples being taken for compliance purposes.

### 15.6 CHASSIS

**15.6.2** No modifications are permitted

**15.6.2** Seam welding is not permitted



**15.6.3** All vehicles shall be in an open condition with the soft top or hood removed

**15.6.4** Bolts, nuts and fasteners may be replaced with equivalent replacements

## **15.7 BODYSHELL and VEHICLE EXTERIOR**

**15.7.1** All bodywork must be in a tidy condition in accordance with Schedule A clause 5.8.

**15.7.2** No front spoiler may be fitted.

**15.7.3** A rear spoiler may be fitted, provided it conforms in size and shape with any of the factory optional spoilers

**15.7.4** All body panels shall be the OEM supplied units or aftermarket equivalents. Alternative materials such as fiberglass, carbon fibre are prohibited.

**15.7.5** Wheel arch inner lips may be folded to provide tyre clearance, provided the outer guard shape is not altered.

**15.7.6** Removal of the following parts is permitted:

- Wheel arch inner plastic linings
- Underbody plastic protection
- Antenna provided the hole is covered
- Indicator lamps fitted to the front guards provided the holes are covered
- Body underseal
- Any unused fittings and brackets

**15.7.7** Headlights may be removed, along with opening mechanism's and frames, but both standard headlight covers must remain, be fixed securely and remain flush with the surrounding body panels. The left hand headlight cover may be replaced by a Mike Shaw Fibreglass induction unit.

**15.7.8** Front Park/Indicator lights may be removed and replaced with lens covers. These must be securely fitted and occupy the same aperture as the original unit. The left side Park/Indicator light assembly maybe removed for induction purposes.

**15.7.9** The main door glass windows, excluding the quarter lights may be removed. Window winders and runners may also be removed.

**15.7.10** The use of tape or any other means to cover body panel gaps is not permitted, unless absolutely necessary when used for a temporary repair following damage.

**15.7.11** It is not permitted to modify the exterior bodywork to channel or duct additional air beneath the car or into the radiator or engine air intake,

**15.7.12** Any protrusions through the firewall shall be covered with suitable rubber fittings or solid panels

**15.7.13** Exterior mirrors may be replaced but only as a pair.

**15.7.14** Fuel filler lid and boot release mechanisms may be modified or removed.

**15.7.15** It is recommended the original bonnet and boot catches be removed and replaced by competition bonnet pins or catches

## **15.7.16**

## **15.8 INTERIOR**

**15.8.1** With the exception of the dashboard assembly and inner door cards, all interior trim and unused brackets may be removed, provided it complies with schedule A. Any sharp edges must be covered.

**15.8.2** The OEM complete dashboard assembly including the steel support frame must remain in the standard location but may be modified for the installation of the roll cage. The radio/heater control panels may be removed provided any holes are covered.

**15.8.3** The driver's seat shall be replaced with a competition seat in accordance with Schedule A. The factory seat rails and support brackets may be modified, reinforced or removed to facilitate replacement seat mounting provided they perform no other function.

**15.8.4** The passenger seat may be removed.

**15.8.5** Instruments and switches may be removed, replaced or supplemented.

**15.8.6** The steering lock assembly shall be removed for Dedicated Motorsport Vehicles and optional for all other vehicles. A replacement steering wheel is permitted in compliance with Schedule A.

**15.8.7** Air conditioning, heater, blower and associated plumbing/fittings may be removed.

**15.8.8** Both doors must retain the original interior door cards. The interior door armrest may be removed to allow for fitting of the roll cage. The standard interior and exterior door catches must be retained and in working condition

**15.8.9** Anti-slip/alternative pads may be fitted to the pedals and a heel plate added

**15.8.10** An internal rear view mirror must be fitted.

**15.8.11** The factory spare wheel and associated tool kit must be removed.

## **15.9 ENGINE**

**15.9.1** The only permitted engine is the Mazda B6 engine with a bore of 78mm and a stroke of 83.60mm.

**15.9.2** Head skimming is free. Cylinder block decking is prohibited.

**15.9.3** Maximum overbore permitted is +0.50mm

**15.9.4** Machining, polishing, drilling and lightening or adding material to engine components is prohibited other than the absolute minimum necessary to allow for recovery of damaged or worn components or balancing during assembly.

**15.9.5** It is permitted to use aftermarket replacement pistons and rings provided they meet OEM form and dimensions, including weight.

**15.9.6** Porting, polishing or any modification of the inlet or exhaust ports of the cylinder heads is prohibited, other than machining of valve seats during assembly.

**15.9.7** OEM camshafts and cam pulleys must be used and may not be modified. The use of vernier cam pulleys is prohibited. Offset camshaft drive pins are prohibited. Only the OEM or equivalent 145-tooth x 22mm cambelt is permitted. Only the OEM or equivalent camshaft tensioner and OEM or equivalent camshaft idler pulley may be used and only in the stock location.

**15.9.8** Cam cover may be altered and the plastic cam belt cover may be removed to expose the cam wheels and belt.

**15.9.9** Only OEM or equivalent unmodified inlet and exhaust valves, valve springs, retainers and hydraulic lifters may be used.

## **15.10 ENGINE ANCILLIARIES**

**15.10.1** Only genuine Mazda or equivalent pattern aftermarket engine mounts may be used. The engine and gearbox must remain in the original location

**15.10.2** The OEM flywheel must be used. Lightening of the OEM flywheel is prohibited, however it is permitted to remove material to reface clutch area to a minimum weight of 7.85kg.

**15.10.3** Clutch disc and pressure plate are free, provided they follow the pattern and diameter of OEM clutch, they mount to the OEM flywheel using the production mounting points and use the OEM or equivalent release bearing and slave cylinder.

**15.10.4** Radiators are free provided they respect the standard core surface area and mount in the standard location.

**15.10.5** Thermostat is free and may be removed, provided the original OEM housing is retained.

**15.10.6** Cooling fan(s) may be removed or replaced

**15.10.7** The original emission, ISC (idle speed control) equipment and associated plumbing may be removed.

## **15.11 INDUCTION SYSTEM**

**15.11.1** The Air Flow Meter shall be the original unit and must not be adjusted from original factory supplied specifications. The unit must not be opened and the top cover and original sealant must remain in place. MX5 Racing NZ will hold a number of air flow meters. Upon request of the Series Scrutineer the competitor is required to remove their air flow meter and fit a unit supplied by MX5 Racing NZ or a unit from a competitor's car. The swapping of air flow meters may be ordered at any time by the Series Scrutineer. Competitors will be allowed one test/practice session to ensure the replacement air flow meter is working correctly.

**15.11.2** The OEM intake duct components and baffle must be used from the throttle body directly to the intake of the standard Air Flow Meter. All components prior to the Air Flow Meter are free.

**15.11.3** The complete inlet manifold system must remain as the factory original with no modifications.

**15.11.4** Air intake cooling. Any artificial lowering of the atmospheric temperature is strictly prohibited

## **15.12 FUEL SYSTEM**

**15.12.1** OEM or equivalent fuel pump is permitted provided it is located in the original position

**15.12.2** Fuel filters are free

**15.12.3** The fuel tank vent system may be modified to prevent potential spillage of fuel.

**15.12.4** Any device or system that alters the temperature or pressure of the fuel from original is prohibited

**15.12.5** Only the OEM MX5 fuel injector, blue 13.8 ohms 205cc, Denso part number 195500-1970 may be used

## **15.13 EXHAUST SYSTEMS**

**15.13.1** The OEM front exhaust manifold must remain and be fitted with the standard operational O2 sensor. It is permitted to remove material from inside of the exhaust manifold to a depth 10mm to align the head to manifold ports. Should such removal result in weakness or leakage it is permitted to locally repair the area by the addition of material to the outside of the manifold only.

**15.13.2** The exhaust pipe rearward of the exhaust manifold is free provided a maximum outside pipe diameter (OD) of 60mm is respected and the exit is in the original location.

**15.13.3** The catalytic converter and rear O2 sensor may be removed

**15.13.4** The rear muffler may be replaced by a Coby bullet style muffler only, provided noise is in compliance with Schedule A.

## **15.14 IGNITION SYSTEM**

**15.14.1** Spark plugs and high tension leads are free, but the ignition coil and layout must remain as per original

**15.14.2** Ignition timing is free

**15.14.3** The ECU shall be the original unit and must not be modified. No alteration to wiring nor additional 'piggy-back' devices may be fitted that may alter the functionality or performance of the ECU, air flow meter, ignition timing or fuel injection. The ECU may be relocated to the front bulkhead under the dash area. MX5RacingNZ will hold a number of ECUs. Upon request of the Series Scrutineer the competitor is required to remove their ECU and fit a unit supplied by MX5RacingNZ or a unit from a competitor's car. The swapping of ECUs may be ordered at any time by the Series Scrutineer. Competitors will be allowed a test/practice session to ensure the replacement ECU is working correctly.

## **15.15 ELECTRICS**

**15.15.1** The tail lights and brake lamps must remain in place and fully functional at all times. Higher wattage bulbs are recommended.

**15.15.2** The battery and its location is free. Battery terminals must be covered.

**15.15.3** The battery and starter motor must be capable of at least 3 repetitive starts.

15.15.4 Redundant wiring, fuses, relays and connectors may be removed.

15.15.5 The OEM ignition switch may be removed and replaced with aftermarket switches

15.15.6 An externally mounted circuit breaker may be fitted.

15.15.7 A rear LED rain light must be fitted in accordance with Schedule A

## 15.16 SUSPENSION

15.16.1 Any single-action damping adjustable shocks with height adjustable spring platforms are permitted. The following options are recommended:

- a. GAZ Gold Professional.
- b. Bilstein
- c. George Stock & Co (springs)

15.16.2 Spring are free

15.16.3 Suspension bushings must be OEM or the equivalent polyurethane bush.

15.16.4 Suspension pickup points must remain as standard

15.16.5 It is permitted to detach but not remove the front or rear anti-roll bars.

15.16.6 The only permitted anti roll bars are the OEM supplied bars:

- Nominal Front Diameter 19.2mm
- Nominal Rear Diameter 12.5mm.

15.16.7 OEM or replica braces may be added to the rear subframe. Replica mounts may be added to the rear subframe for the sole purpose of mounting the braces.

## 15.17 TRANSMISSIONS

15.17.1 The OEM 5 speed gearbox only shall be used. The only permitted transmission and final drive ratios are

### Gearbox Ratios

1 <sup>st</sup>	3.136 : 1
2 <sup>nd</sup>	1.888 : 1
3 <sup>rd</sup>	1.333 : 1
4 <sup>th</sup>	1.000 : 1
5 <sup>th</sup>	0.814 : 1

### Final Drive Ratio

4.300 : 1

15.17.2 It is prohibited to modify the transmission in any way that will alter the operation of any of the internal components.

15.17.3 The conversion from an automatic transmission to an OEM manual 5 speed gearbox and any modification to facilitate such conversion is permitted provided it is solely for that purpose. Any parts required in the conversion shall be OEM as from a manual MX5.

**15.17.4** The differential shall be either the unmodified OEM “open” or “viscous LSD (VLSD)” unit. Any other type of limited slip differential or locked diff is prohibited.

**15.17.5** Diff mounting bushes must be OEM or equivalent polyurethane bush

**15.17.6** Any shift knob may be used, including a short shift lever.

## **15.18 BRAKES**

**15.18.1** Brake pads are free.

**15.18.2** Brake lines and hoses are free, provided Schedule A compliance is maintained. Steel braided flexible hoses are recommended.

**15.18.3** Brake rotors are free provided they are ferrous and respect the original diameter and thickness. Slots, grooves and cross drilling is not permitted.

**15.18.4** The OEM brake calipers must be used in the original locations

**15.18.5** Steel backing plates may be modified or removed. Any form of fabricated brake ducting is prohibited.

**15.18.6** Vehicles fitted with Anti-lock braking systems must have those disabled or removed.

**15.18.7** The handbrake must remain standard and functioning.

**15.18.8** An aftermarket or adjustable brake bias valve is not permitted.

## **15.19 WHEELS and STEERING**

**15.19.1** Manual or power steering may be used provided the ratio remains standard. It is permitted to convert a power steering rack to manual. Unused power steering components and fittings may be removed

**15.19.2** Wheels are free to a maximum size of 15”x7” and must fit within the standard arches.

**15.19.3** Wheel spacers are prohibited and the OEM wheel studs must be used

## **15.20 CONTROL TYRES**

**15.20.1** Tyres are to be Hankook Ventus RS4 195-50R 15 and shall have a minimum tread depth in accordance with Schedule A 4.9 (3) (b) All tyres shall have a minimum tread groove depth of 1.5mm as defined by the manufacturers tread depth indicators within all grooves around the entire circumference of the tyres road contact surface.

Note: Toyo R888 and R888R 205/50/15 tyres are now obsolete. Points will not be awarded to drivers using these tyres

**15.20.2** The following treatments/modifications are specifically prohibited:

- Hand cut tread grooves;
- Tyre warmers;
- Chemical treatments or any means to artificially enhance tyre performance.

## **16. OFFICIAL SEALS**

**16.1 Provision for fitment of seals:** All vehicles shall have provisions for wire seals to be affixed to the following positions. Accordingly a 3.0mm hole shall be pre-drilled in readily accessible positions in such a manner that the relevant part cannot be removed without breaking the affixed seal.

1. Engine and head joint.
2. Gearbox side – two adjoining bolts
3. Final drive head – two adjoining bolts

**16.2** All cars may have seals fitted during the season as directed by the Series Scrutineer.

**16.3 Removal of seals:** Official Seals shall not be tampered with, broken or removed during the series or within 30 days of the final round unless written permission is obtained by the series scrutineer. Any seal(s) removed without permission shall immediately forfeit all points earned in the series to date.

## **MX5RacingNZ is supported by and recommends:**

Manawatu Car Club. Jeff Braid

[manawatucarclub.org.nz](http://manawatucarclub.org.nz)

027 477 3337

Racetech NZ

[www.racetech.co.nz](http://www.racetech.co.nz)

04 939 0552

GAZ Racing Shocks NZ

[julian.hardy@xtra.co.nz](mailto:julian.hardy@xtra.co.nz)

027 4434343

Coby performance exhausts

[www.cobyexhausts.co.nz](http://www.cobyexhausts.co.nz)

07 849 1765

Tremain Energy

[tremainworkshop@inspire.net.nz](mailto:tremainworkshop@inspire.net.nz)

0800 291 494

**Discounted Hankook Tyres available from**

[tremainworkshop@inspire.net.nz](mailto:tremainworkshop@inspire.net.nz)

